

	kg	m	Front axle	Rear axle
Plated weight	12000			
Kerb weight	8230		3500	4730
Wheel base		5		
1 no. Passenger Truck full of diesel & Ad blue	80		80	
Plastic @ ~ 66% of 640kg COG Front Axle Load W1 Rear Axle Load W2	417	0.5	42	375
Paper @ ~ 66% of 1500kg COG Front Axle Load W1 Rear Axle Load W2	979	2.65	519	460
Food @ ~ 66% of 1700kg COG Front Axle Load W1 Rear Axle Load W2	1109	1.6	355	754
Glass 1 @ ~ 66% of 1200kg COG Front Axle Load W1 Rear Axle Load W2	397	0.65	52	345
Glass 2 @ ~ 66% of 1200kg COG Front Axle Load W1 Rear Axle Load W2	384	-0.9	-69	453
Cardboard @ ~ 66% of 600kg COG Front Axle Load W1 Rear Axle Load W2	391	-2.05	-160	551
Additional @ ~ 66% of 20kg COG Front Axle Load W1 Rear Axle Load W2	13	0	0	183
Total weight	12000		4332	7668
Plate Weight	12000		4480	8480
Available load	0		148	812

Romaquip Kerb-Sort 5000mm Standard 2450mm wide DAF LF45 EURO 6 12T 5000mm wheelbase, paper, food, glass 1, glass 2 and cardboard.			
Payload	3770kg*	Length	9190mm
Collection space	37.2m³	Height	3450mm
Width	2450mm		

Section	Volume (m3)	Weight of recyclables (kg)	Theoretical Density ** (kg/m3)
Top deck	19	646 (Mixed plastics), 779 (Commingled tetra)	34,41
Paper	4.4	1716	390
Food	2.6	1768	680
Glass 1	2.6	650	250
Glass 2	2.3	550	250
Cardboard	4.8	600-975	125-200
Additional	1.5	375	250
Total	37.2	6813	

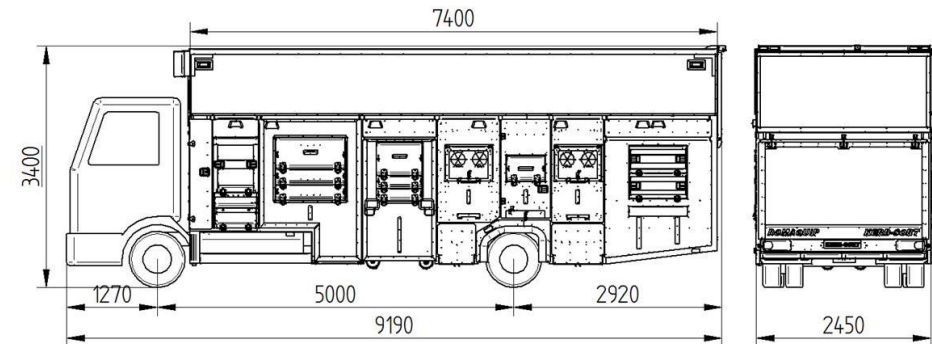

Specifications subject to change without prior notice

* Allison 2500 Fully Automatic Transmission- 200kg, High compaction cardboard- 150kg,

Glass noise reduction system- 70kg, Plastic flaps- 10kg, 2nd passenger- 80kg

** Actual density values are to be applied by the customer relative to their experience of their operation